



RISER & DRILLING SYSTEMS

OR-6C Connector

Introduction

Oil States Industries is a world leader in the design and manufacture of advanced connection systems for off-shore use. Our connectors provide fast make-up and high performance ideal for SCRs, TLPs, tethers, conductors, casing, new and replacement caissons, HP risers, pipelines and jacket piles. Oil States is a proven provider of riser components for deep water, production, drilling and completion risers. We also offer comprehensive riser system design services for completion, drilling, subsea and surface equipment to complement our field-proven connector technologies.

Marine Drilling Riser System

Marine drilling risers provide a conduit from the drilling vessel to the subsea BOP. Drilling operations and fluids pass through the riser to the subsea well, with drilling mud and returns traveling back to the vessel. Risers typically include a riser main pipe; box and pin connectors; choke and kill (C&K) lines; and auxiliary lines.

OR-6C Connector

Oil States' OR-6 riser connectors are designed in-house and are lab tested in accordance with API 16R, and certified by DNV. These dog-type connectors are simple to operate and field proven to provide high pre-load and fast makeup of the riser connection.

Features

- Simple, lightweight design
- Low make-up torque: 1,000 ft.-lbs
- Highly pre-loaded connection
- 1.25M lbs. tensile load rating in accordance with API 16R

OR-6 Risers

OR-6 risers run 'pin up' and 'box down' with make-up being achieved by way of a spider, gimbal sized to suit the vessel

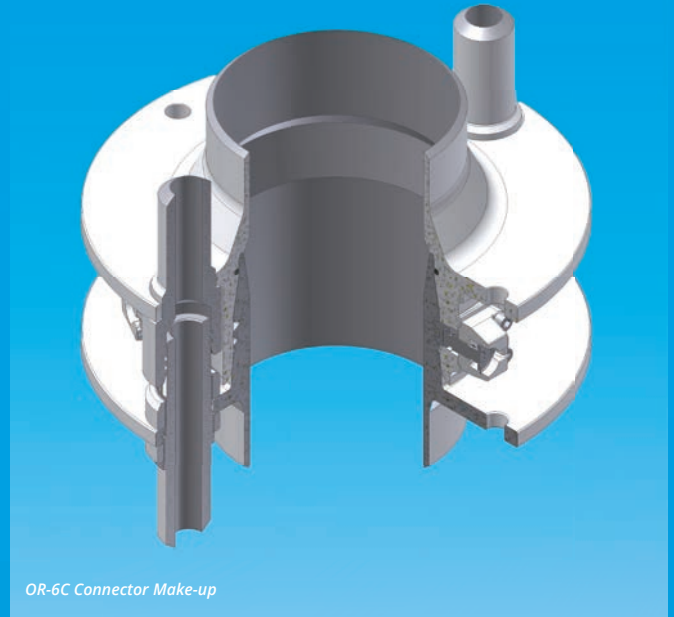

OR-6C Connector Make-up

supplied rotary table. The riser's main tube is supplied in 5 ft. pup joints up to 90 ft. long, and can be configured for slick or full joint buoyancy fit out.

OR-6 riser connectors are mounted on the riser connector box. When actuated, these 6 dogs mate with a profile machined into the OD of the riser pin. Once made-up, this connection supports all tensile bending and fatigue loads.

C&K, booster, auxiliary and hydraulic lines are attached to the riser connector's pin and box with lock and jam nuts. All lines are interchangeable with the C&K lines being designed for working pressures of either 10,000 or 15,000 PSI. Booster and hydraulic lines are designed for working pressure of 3,000, 5,000 or 6,000 PSI.

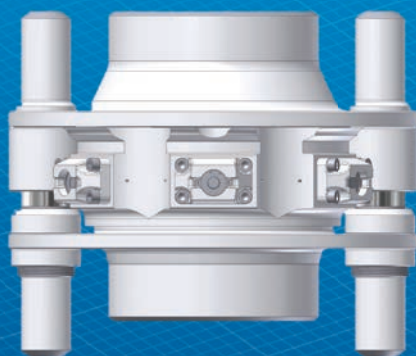

OR-6C Connector Assembly





RISER & DRILLING SYSTEMS

OR-6C Connector

The seal grooves of the female stab boxes in the C&K and booster lines are inlaid when required with Inconel to prevent corrosion.

The male stab pins of all lines are inlaid with Stellite to increase wear resistance during stabbing.

Handling/Tooling

Manual riser handling and test tools are available for flanged risers. Horizontal lifting/handling attachments, such as spreader bars and shackle lifting tools are also available.

Qualification

- OR-C risers are designed and manufactured in accordance with API 16R (riser connectors) and API 16F (main risers)
- C&K and booster lines are designed to meet H2S (sour gas) service per NACE MR-01 75
- Design verification review packages are reviewed and approved by DNV
- DNV/ABS certification is available

Testing

Finite element analysis has been performed on the riser connector/locking dogs.

Prototype testing of the riser connectors are carried out at Oil States' UKAS- accredited test laboratory; witnessed and approved by DNV.

Oil States Capital Drilling Equipment includes the following:

- Spider Assembly
- Gimbal Assembly
- Diverter System
- FlexJoints™
- Telescopic Joints
- TJ Support Ring Assembly
- Termination Joint
- LMRP and Wellhead LynxGrip™ Connector

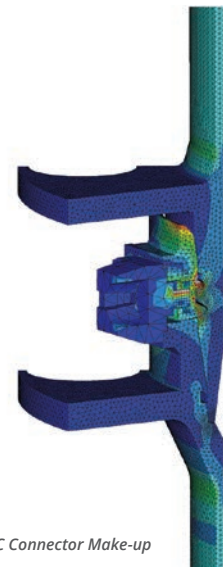

OR-6C Connector Make-up

OIL STATES INDUSTRIES RISER & DRILLING SYSTEMS

Sales, Engineering & Manufacturing
EUROPE & EURASIA
 2 Heartlands Terrace
 Heartlands Business Park
 Whitburn, West Lothian
 EH47 05F
 Scotland, UK
 Tel +44 1506 896 000

ASIA
 42-H Penjuru Road
 Singapore 609158
 Tel +65 6773 7555

Regional Sales
EUROPE & EURASIA
 Moss Road
 Gateway Business Park
 Nigg, Aberdeen
 AB12 3GQ
 Scotland, UK
 Tel +44 1224 290 000

5 Allée des Mésanges
 13012 Marseille, France
 Tel +33 491 95 60 51

Vagif Mustafazade Street 6/10
 1st Floor, Sahibtac Business Centre
 Old City, Baku AZ1010
 Azerbaijan
 Tel +994 12 598 1125

SOUTH AMERICA
 02 Corporate & Offices
 Ed. Evolution III
 Bloco 2, Sala 105
 Av. Paisagista José Silva de Azevedo
 Neto, 200
 Barra da Tijuca, RJ Brazil
 CEP 22775-056
 Tel +55 21 3503 2400

MIDDLE EAST
 HDS Tower, Unit 2209, Cluster F
 Jumeirah Lakes Towers
 Dubai, United Arab Emirates
 Tel +971 4 452 8482

riser.connectors@oilstates.com

oilstates.com

